

20 GN 2/1 ELECTRIC CONVECTION / STEAM OVEN
FORNO CONVEZIONE / VAPORE ELETTRICO 20 GN 2/1

PNC	Model	Ref	Group	Level	Page	Notes
236205	FCZ202EKA	q	FCZ	Level K	2...11	STD (400V - 3N)
237205	FCZ202ETA	i	FCZ	Touch	2...11	STD (400V - 3N)
238205	FCZ202EBA2	l	FCZ	Level B	2...11	STD (400V - 3N)
239205	FCZ202ECA2	m	FCZ	Level C	2...11	STD (400V - 3N)
266205	AOS202EKA1	p	AOS	Level K	2... 11	STD (400V - 3N)
266355	AOS202EKR1	a1	AOS	Level K	2...11	400V 3N 50/60 HZ AUS
267205	AOS202ETA1	a	AOS	Touch	2...11	STD (400V - 3N)
267235	AOS202ETC1	e	AOS	Touch	2...11	200V 3N 50/60 HZ JAPAN
267285	AOS202ETM1	b	AOS	Touch	2...11	America (208V - 3)
267305	AOS202ETK1	d	AOS	Touch	2...11	UK (400V - 3N)
267325	AOS202ETV1	n	AOS	Touch	2... 11	USA (480V - 3)
267355	AOS202ETR1	b1	AOS	Touch	2...11	400V 3N 50/60 HZ AUS
268205	AOS202EBA2	f	AOS	Level B	2...11	STD (400V - 3N)
268235	AOS202EBC2	r	AOS	Level B	2...11	200V 3N 50/60 HZ JAPAN
268305	AOS202EBH2	g	AOS	Level B	2...11	UK (400V - 3N)
268355	AOS202EBR2	c1	AOS	Level B	2...11	400V 3N 50/60 HZ AUS
269205	AOS202ECA2	h	AOS	Level C	2...11	STD (400V - 3N)
269305	AOS202ECK2	o	AOS	Level C	2...11	UK (400V - 3N)
269355	AOS202ECR2	d1	AOS	Level C	2...11	400V 3N 50/60 HZ AUS



PLATON SERVICE
8 (800) 500-3434
www.platonservice.it

Pag	Index	Indice	Note
2	Oven cabinet and door.	Cella forno e porta	
3	Water system	Impianto idraulico	
4	Boiler	Boiler	
5	Electrical components	Componenti elettrici	
6	Accessories	Accessori	
7...11	Spare parts list	Lista ricambi	

Brand/Marchio: All
Factory code: 9PDD

From sr. Nr/ Da Ser. Nr.: ***
From status level / Da scatto: 07

Page: 1

Ed. 2014 10

Doc. Nr.: **875400Y00**

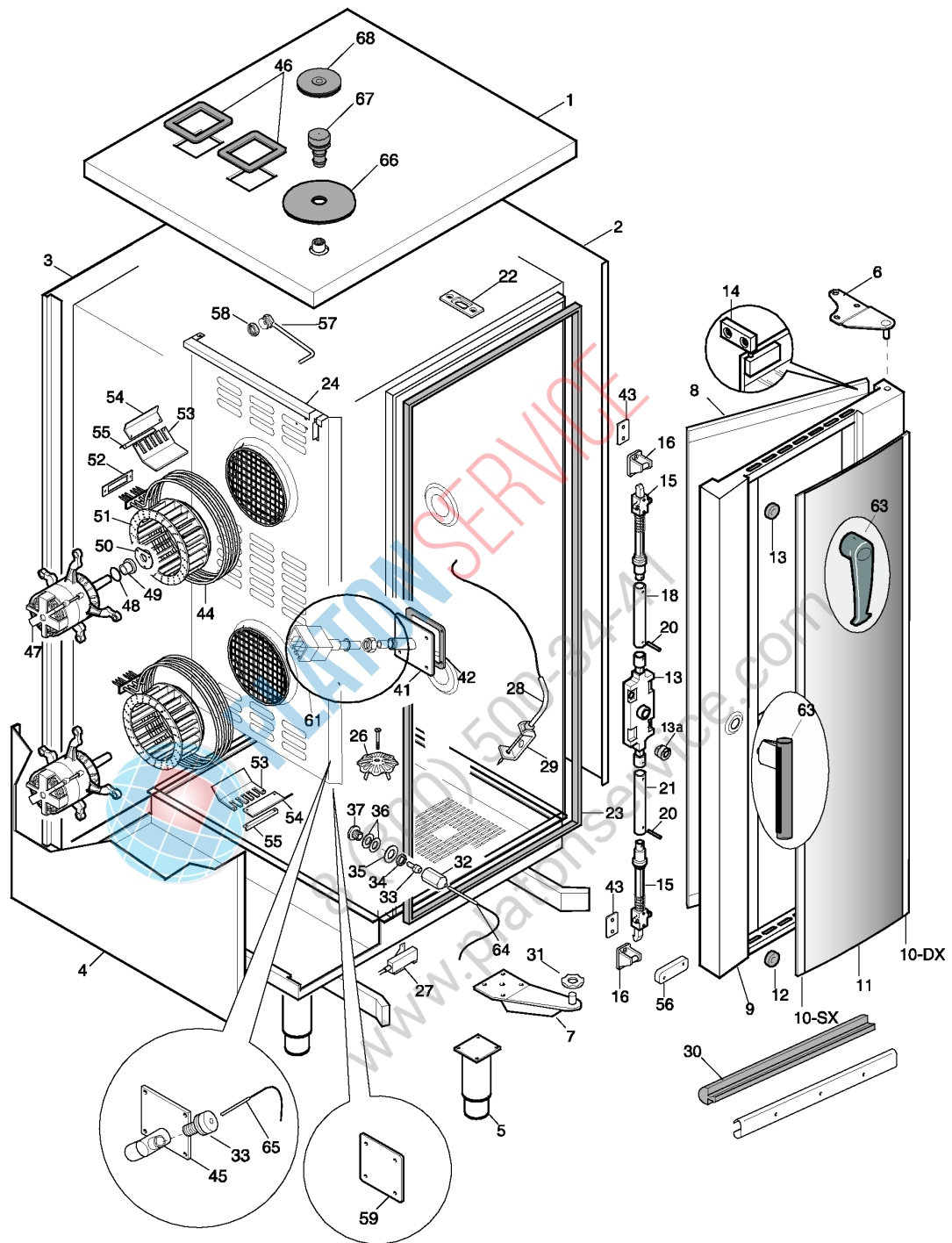

From sr. Nr/ Da Ser. Nr.: ***
 From status level / Da scatto: 07

Page: 2

Ed. 2014 10

Doc. Nr.: **875400Y00**

??????		267205									
??????		875400Y00		????????? 2		Oven cabinet and door					
.		Alias		S			.				(Euro)
0001	0C4305	0873871302			D			LID; ASSY; AOSQ 20 1/1 ELT	For Lev. C,K		741,00
0001	0C6184	0530892000						LID; ONE 202E			216,20
0002	0C6206	0538832100			D			RIGHT SIDE; ONE 202			276,10
0003	0C6208	0538834100						BACK PANEL; ONE 202			228,40
0004	0C6210	0538834600						LEFT SIDE; ONE 202			251,70
0005	0C4824	0806871700		S	C			ADJUSTABLE FOOT; 2" INOX; 190-250MM			39,99
0006	007086	0512816003						HINGE			48,92
0007	0C2483	0806843301						LOWER HINGE; ASSY			86,28
0008	0C4870	0873870202		S				GLASS; ASSY; INT. LW 202 AOSQ			207,10
0009	0C5068	0873860410	0C6604		D			DOOR ASSEMBLY; ONE 202			
0010	0C4970	0530873600						PROFILE; DX ONE 20X			54,71
0010	0C4971	0530873700						PROFILE; SX ONE 20X			56,64
0011	0C4946	0574818801						DOOR GLASS; EXT; ONE 202	For FCZ		181,70
0011	0C6562	0574400600						DOOR GLASS; 1578X655MM; EXTERNAL	For AOS		218,20
0012	006976	0543828001		S				SHOCK ABSORBER			4,33
0012	0C4119	0856808701		S				DOOR CLOSING ASSY; AOS-Q 20			206,00
0013	003824	0853821500		S				CENTRAL LOCK MECHANISM			91,00
0014	007007	0806822000		S				HINGE			16,36
0015	003822	0853821600	OK2246					HOOK; CLOSING DOOR			
0016	0C3802	0538804900		S				CATCH; FCP 20			43,44
0018	0C4309	0513800501		S				SLIDE ROD; UPPER			22,23
0020	0H6043	0214593100		S				SPRING COTTER; 3X16			1,02
0021	0C4310	0513801100		S				SLIDE ROD; LOWER			32,28
0022	0C4088	0543839700		S				GASKET			8,13
0023	0C1889	0543835100		S				DOOR GASKET; 1438X630MM			132,00
0024	0C4622	0831847304						SUCTION WALL; AOSQ 202 ELT			403,00
0026	0C2769	0518808700						BOTTOM STRAINER			13,26
0027	049621	0654600000		S	C	+		REED SWITCH			15,00
0028	0C6573	0830400A00		S				CORE PROBE; SINGLEPOINT	For Level B, C,K		145,10
0028	0C6574	0830400B00		S				CORE PROBE; MULTIPOINT	For Level Touch		234,50
0029	0C1505	0527865201						SUPPORT			7,29
0030	0C4131	0543838001		S				DOOR GASKET; LOWER; L=807 MM			70,04
0031	002653	0510815700		S				SPACER FOR HINGE			13,62
0032	006991	0516855300						NUT			22,43
0033	0C4872	0543842600		S				PLUG; FOR SENSOR			7,29
0034	020997	0214105101		S				LOCK NUT			1,25

??????	267205									
??????	875400Y00	???????? 2	Oven cabinet and door							
.		Alias		S			.			(Euro)
0035	002700	0508838701		S				WASHER		3,07
0036	002701	0516809301		S				INSULATOR		3,59
0037	002623	0516809400		S				PIPE FITTING		10,04
0041	0C4244	0806857201		S				FLANGE; FOR LAMBDA SONDE	For Level Touch	40,09
0042	0C4093	0543838300		S				GASKET		11,09
0043	0C4122	0538807400		S				THICKNESS		8,77
0044	0C1173	0617828000	0C6502					HEATING ELEMENT; 400V 8KW	For 400V Version	
0044	0C2241	0617829300						HEATING ELEMENT; 8KW 208V USA	For 208V Version	153,30
0044	0C2242	0617829900						HEATING ELEMENT; 8KW 240V USA	For 240V Version	181,70
0044	0C6502	0617400901	0C5365	S		+		HEATING ELEMENT; 400V-8000W	a,d,f,g,i,l,p,q	
0044	0C9858	0617400C00						HEATING ELEMENT; 200V 8000W	For Japan Version	85,36
0045	0C4311	0806856300						HOSE; WITH FLANGE; AOSQ 20	For Level B	179,70
0046	0C1194	0543832100		S				GASKET		7,92
0047	0C6563	0611810000		S				MOTOR; 200-240V/750W		360,30
0047	0C6704	0611400500		S				MOTOR; 200V/240V-750W 50/60HZ	For 208V,240V 60Hz, Japan Version	350,20
0048	002873	0543816700		S				O-RING; ØI=MM.28,17X3,53		2,43
0049	002699	0516808902		S				BEARING; FOR MOTOR SHAFT		20,50
0050	0C4138	0538815401		S				FLANGE		5,81
0051	0C6464	0835400900		S				FAN BLADE		223,30
0052	002689	0543816501		S				HEATING ELEMENT GASKET		26,09
0053	0C3830	0527833700		S				SUPPORT		14,58
0054	006256	0503891801		S				BLADE; FOR FIXING HEATING ELEMENT		15,20
0055	006253	0503897402		S				ANGLE		9,19
0056	049627	0699603700		S				MAGNET		9,82
0057	0C4976	0856828500						WATER PIPE; ONE 102/202 LIV.C	For Level C,K	42,43
0058	0C6228	0516887101		S				PIPE FITTING	For Level C,K	18,88
0059	0C4857	0527898900		S				PLAQUE	For Level C,K	6,33
0061	0C6465			S		Kit	PDD2011-10	LAMBDA PROBE; KIT	for level TOUCH	173,60
0063	0C6568	0830400200		S				DOOR HANDLE	for AOS Group	77,34
0063	0C8719	0806873601	0C9149	S		+		DOOR HANDLE; COMPLETE	for FCZ Group	
0064	0C6538	0830898902		S				TEMPERATURE PROBE; L=500MM	For level B-C-K	37,66
0064	0C7028	0830400N00		S				SENSOR	for level TOUCH	42,12
0065	0C6539	0830899101		S				THERMOCOUPLE PROBE; L=1100MM; STRAIGHT		40,19
0066	0C7016	0543400900		S				GASKET; ØE=74MM; ØI=17MM; H=12,5MM		4,01
0067	002692	0543816601		S				CAP; DESCALING LOAD IN THE BOILER		6,76
0068	0C4965	0543843201						BUFFER		12,04

??????	267205								
??????	875400Y00	???????? 2	Oven cabinet and door						
.		Alias		S			.		
013a	0C8627	0806873501		S				BUSHING	(Euro) 32,28



PLATON SERVICE

8 (800) 500-34-47

www.platonservice.com

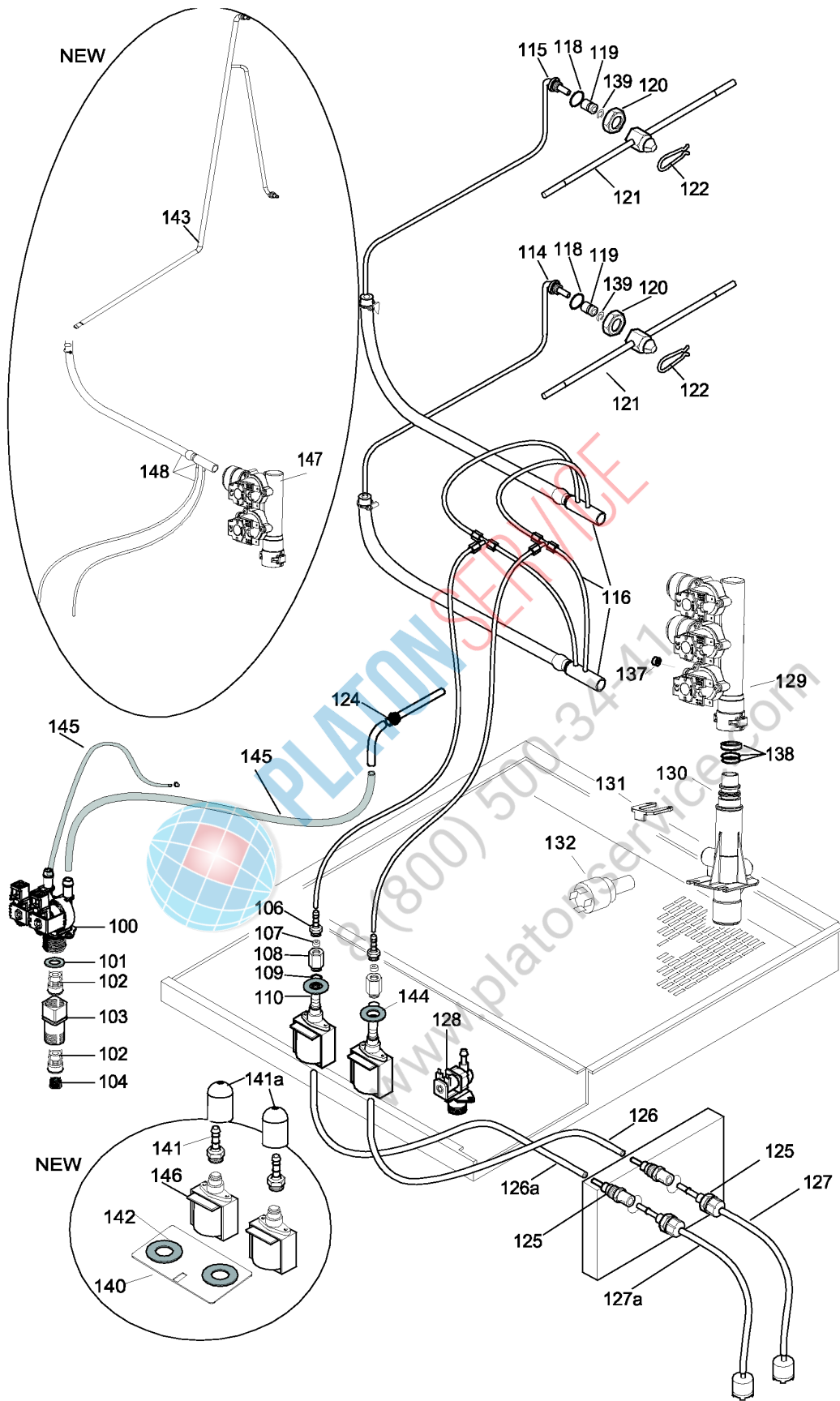

From sr. Nr/ Da Ser. Nr.: ***
 From status level / Da scatto: 07

Page: 3

Ed. 2014 10

Doc. Nr.: **875400Y00**

??????		267205									
??????		875400Y00		????????? 3		Water system					
.		Alias		S			.				(Euro)
0100	0C5517	0696808400		S	C			WATER SOLENOID VALVE; 2 VIE/180 5/L MIN	for Level Touch,B		33,36
0101	0C4096	0543840600		S				FILTER GASKET	for Level Touch,B		1,27
0102	0C2312	0549801800		S				NONRETURN VALVE	for Level Touch,B		5,86
0103	0C2313	0516879400		S				PIPE FITTING	for Level Touch,B		29,54
0104	0C4096	0543840600		S				FILTER GASKET	for Level Touch,B		1,27
0106	0C4198	0516896102		S				RUBBER HOLDER; G1/4" DIA 4 MM	for Level Touch,B		13,30
0107	0C1117	0544809000		S				NONRETURN VALVE	for Level Touch,B		6,90
0108	0C1116	0516871900		S				FITTING; RINSE AND DETERGENT PUMPS	for Level Touch,B		10,29
0109	0C1935	0543832300		S				O-RING; ØI=6,75X1,78 MM	for Level Touch,B		1,02
0110	0C2341	0680801201	0C6947					PUMP	50 Hz		
0110	0C2342	0680801301		S				ELECTRIC PUMP; 120V 60HZ 32W	60 Hz		60,39
0110	0C5371		0C9067			Kit		ELECTRIC PUMP; KIT; 208-240V	For 50 Hz		
0114	0C6031	0806871100		S				DUCT; ASSY			41,21
0115	0C6047	0806870900						PIPE			110,60
0116	0C6024			S				HEATING ELEMENT; 200W-17000W			283,20
0118	0C4201	0543841400		S				GASKET; 17X22X1,5			2,53
0119	0C4467	0516898301		S				BUSHING; FCS 6			10,77
0120	0C4202	0516892301		S				LOCK NUT; INOX M16X1.5X6H			5,33
0121	0C5503	0806873900	0C8317					WASH ARM; ASSY; L=422MM			
0122	007026	0518807100		S				SPRING			14,25
0124	007075	0H22982800						PIPE	for Level A,B		29,84
0124	0C4978	0856828700						WATER PIPE; ONE 102-202 LIV.C	for Level C,K		28,93
0125	0C1127	0831811702		S				EXTERNAL CLEANING SYSTEM GROUP; L=1600MM			119,80
0126	0C9799							HOSE; BY METER; 6X8 RED			3,74
0127	0C9797							HOSE; BY METER;4X6 RED			3,18
0128	0C5515	0696808200		S				WATER SOLENOID VALVE; 1 VIA/180°	for Level C,K		15,86
0128	0C6170	0696808801		S				SOLENOID VALVE; 1VIA; 230V 50/60HZ	for Level B		15,86
0129	0C6371	0696400200			D	PDD2012 -17		WATER DISTRIBUTOR; 1U-230V 2U-110V 50/60	For 60Hz		85,56
0129	0C6372	0696808700			D	PDD2012 -17		WATER DISTRIBUTOR; 3 OUTPUT; 230V 50/60H	For level TOUCH,B		78,36
0129	0C6407	0696400400			D	PDD2012 -17		WATER DISTRIBUTOR; 2U.230V- 50/60HZ	for Level C,K		69,02
0130	0C6370	0831857200		S				MANIFOLD; ASSY			42,43
0131	0C6222	0546825100		S				SAFETY DEVICE			6,26
0132	0C6217	0646817200		S				PRESSURE SWITCH; GP600			33,50
0137	0C6375			S		Kit		FLOW REDUCER; KIT 4PCS			11,67
0138	061303			S				RING			1,02
0139	0C6421	0219035015		S				SPRING RING			1,02

??????	267205								
??????	875400Y00	???????? 3	Water system						
.		Alias		S			.		(Euro)
0140	0C7924	0505401R00						FIXING PLAQUE	6,22
0141	0C8348	0544400C01		S				RUBBER HOLDER; DIA.5MM 1/8"	
0142	0C7925	0543400R00		S				CABLE GROMMET; ØINT 24.6 ØEST 38	15,23
0143	0C8328	0805402400						MAIN PIPE	80,90
0144	005382	0246530100		S				GROMMET; DIA.22	1,99
0145	0C5829	0544819400	0C4832	S				TUBE; BLU; 10X17; BY METER	
0146	0C8347	0686400100	0C9067					PUMP; 230-240V 50-60HZ; UL	Up to 4441...
0146	OCA112	0686400201						PUMP;230V/50HZ 240V/60HZ UL;CLEANING SY	From 4451...
0147	0C8683	0835400L00		S				WATER INLET GROUP; 220 240V UL	122,80
0147	0C8684	0835400M00		S				WATER INLET GROUP; 220 240V UL	For level C,K 102,50
0148	0C8185	0805400A02		S				MANIFOLD; ASSY	36,64
126a	0C9800							HOSE; BY METER; 6X8; LIGHTBLU	3,74
127a	0C9798							HOSE; BY METER; 4X6; LIGHTBLU	3,18
141a	0C9538	0546400J00		S				PROTECTING CAP; BLACK	



PLATON SERVICE
8 (800) 500-34-41
www.platonservice.com

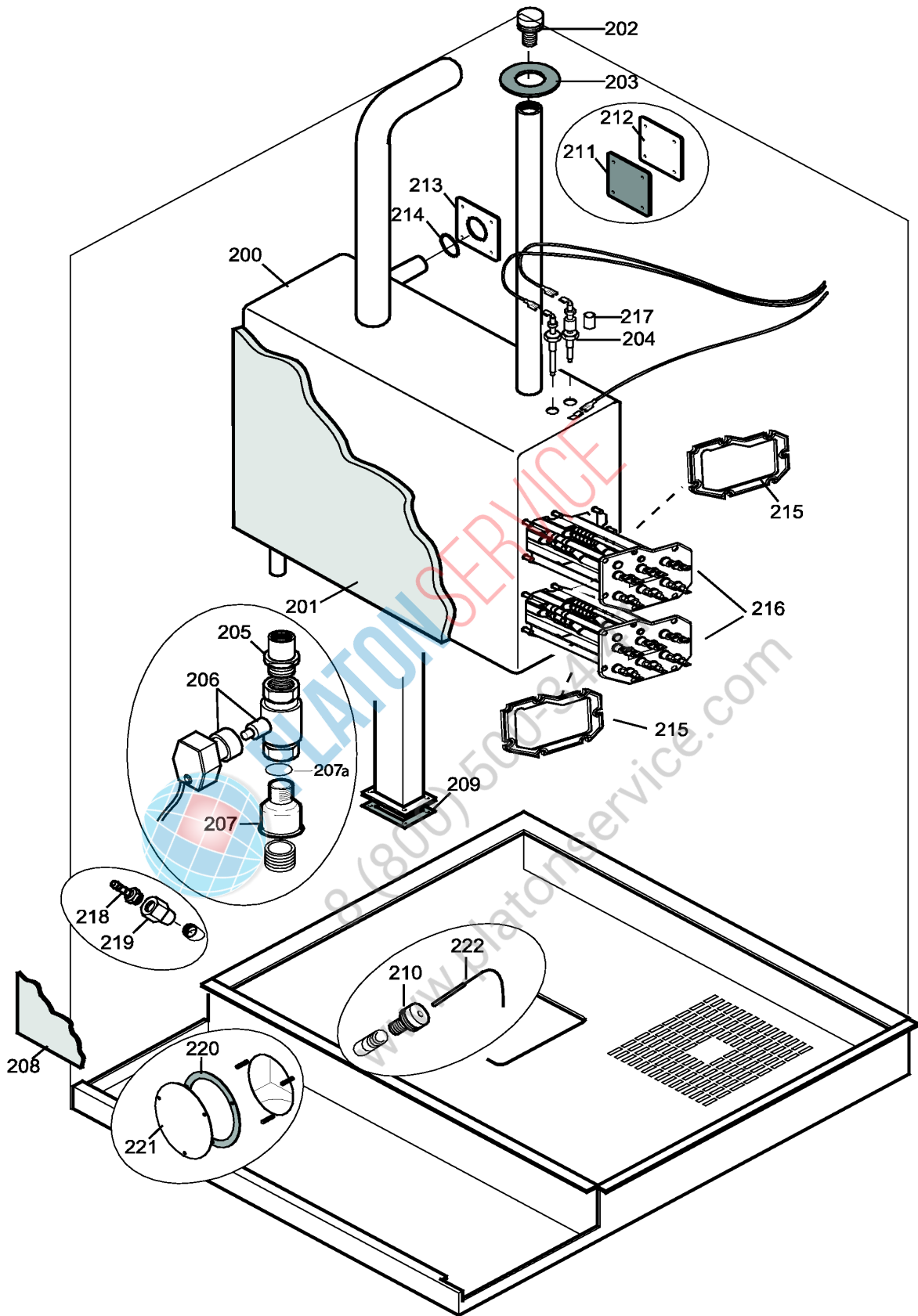

??????	267205								
??????	875400Y00	???????? 4	Boiler						
.		Alias		S			.		(Euro)
0200	0C9665	0878401600						BOILER; KIT; ELT 202	1 332,00
0201	0C5838	0569807100						BOILER INSULATION; ELT ONE 202	117,70
0202	002692	0543816601		S				CAP; DESCALING LOAD IN THE BOILER	6,76
0203	0C4965	0543843200						BUFFER	For Lev. C,K 12,04
0203	0C7016	0543817500		S				GASKET; ØE=74MM; ØI=17MM; H=12,5MM	4,01
0204	0C7128	0831858600		S				LEVEL PROBE	34,71
0205	007117	0516809501		S				CONNECTION	15,81
0206	0C0882	0696804201		S				MOTOR-OPERATED VALVE; 3/4" 230V 50/60HZ	144,10
0206	0C5518	0696808500		S				BALL VALVE; 3/4' USA 240V 50/60HZ	For 60 Hz Version 145,10
0207	007040	0511817600		S				CONNECTION	11,09
0208	0C4141	0560845602						INSULATOR; FOR AIR-BREAK EL.LW 20 2/1	66,18
0209	0C4133	0543832400						GASKET; FOR AIR-BREAK	31,97
0210	0C4872	0543842600		S				PLUG; FOR SENSOR	7,29
0211	0C4858	0527899100						FLANGE; FOR BOILER; 20 2/1	For Lev. C,K 10,14
0212	0C4964	0543843100						GASKET	For Lev. C,K 39,79
0213	0C4142	0538806601						FLANGE; FOR BOILER	15,95
0214	0C3128	0543832500		S				O-RING; 153-VITON 49.2*3.53	4,85
0215	0C5834	054384480		S				GASKET; BOILER HEATING ELEMENT	19,69
0216	0C5822	0617837200						HEATING ELEMENT; 208V-20000W	For 208V Version 288,30
0216	0C5825	0617837800						HEATING ELEMENT; 240V-20000W	For 240V Version 299,40
0216	0C5841	0617836500		S				HEATING ELEMENT; 400V-24000W	For 400V Version 211,10
0216	0C6027	0617839502						HEATING ELEMENT; 200V-20000W	For Japan Version 291,30
0217	055347	0515857001		S				SPACER; H=11,5MM	5,81
0218	0C5564	0510828000		S				RUBBER HOLDER; 1/4"; FOR TUBE DIA.10MM	5,33
0219	0C3797	0516889400		S				NOZZLE; ELPIS 1/4"FD10 3/8"M	21,01
0220	0C7033	0543400000		S				GASKET	for level TOUCH 17,95
0221	0C3443	0J89061403						WASHER; FOR DOOR	15,84
0222	0C6539	0830899101		S				THERMOCOUPLE PROBE; L=1100MM; STRAIGHT	for Level TOUCH e B 40,19
207a	002874	0543816800		S				O-RING; ØI=31,34X3,53 MM	For Touch, Level B version 3,48

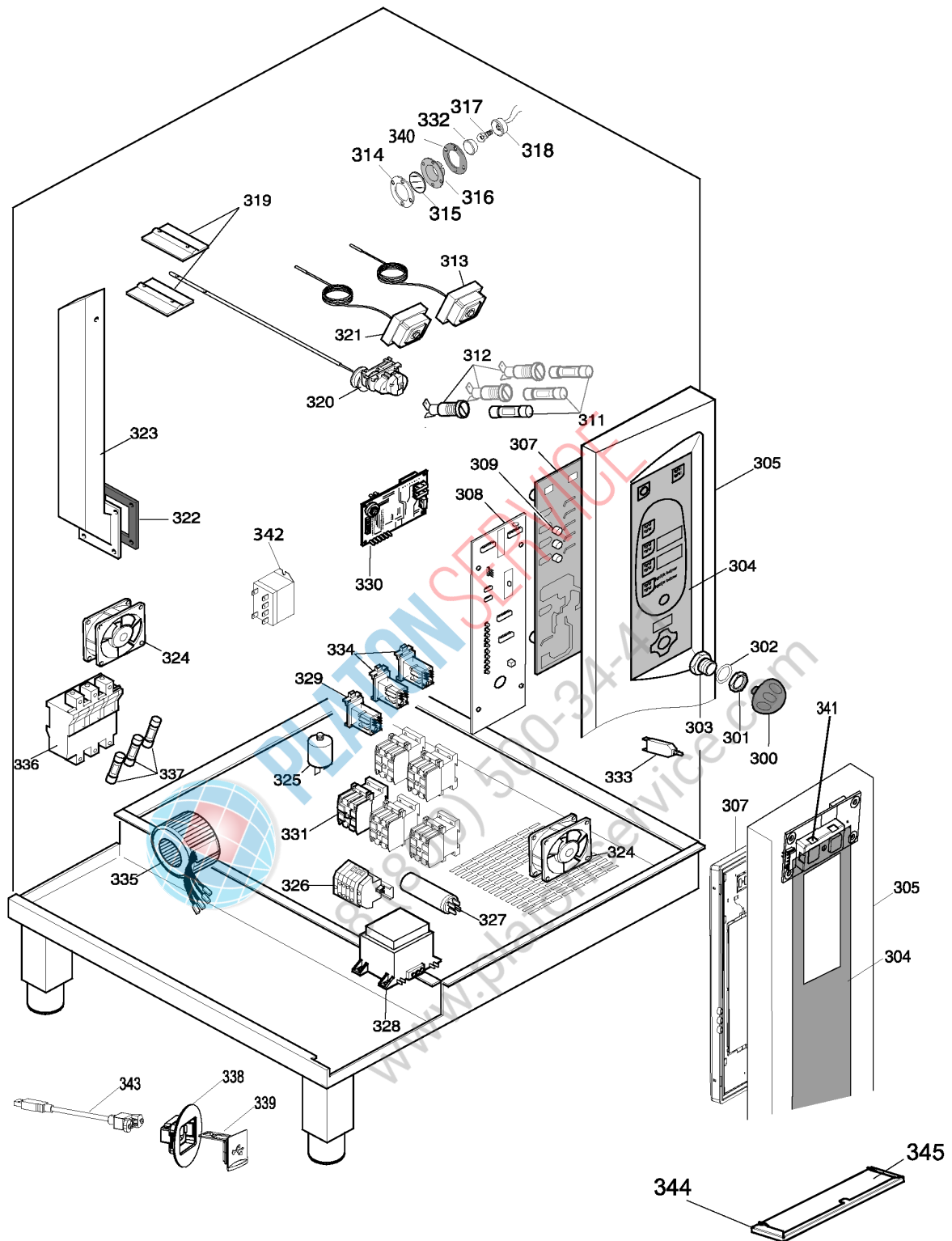

??????	267205										
??????	875400Y00	???????? 5					Electrical components				
.		Alias		S			.			(Euro)	
0300	0C5600	0806874001	0C4875						KNOB		
0301	051263	0214114900		S					LOCK NUT	3,80	
0302	002727	0508836400		S					WASHER	1,02	
0303	002662	0516807301		S					BUSH	6,02	
0304	0C4948	0675855001							ADHESIVE MEMBRANE; ONE; LIV.B	for Level B FCZ Ver.	67,90
0304	0C4949	0675855102							ADHESIVE MEMBRANE; ONE; LIV.C	for Level C FCZ Ver.	56,43
0304	0C6550	0548400600		S					ADHESIVE MEMBRANE	AOS Ver.	111,70
0304	0C6551	0548400B00							ADHESIVE MEMBRANE	FCZ Ver.	59,28
0304	0C6554	0548400G00							ADHESIVE MEMBRANE	for Level B AOS Ver.	121,80
0304	0C6557	0548400K00							ADHESIVE MEMBRANE	for Level C AOS Ver.	197,90
0304	0C8707	0548401H00							ADHESIVE MEMBRANE; TOUCHSCREEN 20 ELUX '	For level touch "K" AOS ver.	221,30
0305	0C4911	0873896902							CONTROL PANEL; ONE 202 LIV.B	for Level B FCZ Ver.	308,60
0305	0C4912	0873897002							CONTROL PANEL; ONE 202 LIV.C	for Level C FCZ Ver.	308,60
0305	0C6589	0870400C00							CONTROL PANEL; 202 LIV.B	for Level B AOS Ver.	338,00
0305	0C6598	0870400Q00							CONTROL PANEL	for TOUCH FCZ Group	292,30
0305	0C6599	0870400R00							CONTROL PANEL; 202 LIV.C	for Level C AOS Ver.	338,00
0305	0C7032	0875401B01							CONTROL PANEL; CPL.; WITH MEMBRANE	for TOUCH AOS group	463,90
0305	0C8708	0875401R00							CONTROL PANEL; COMPLETE W/MEMBRANE	For level Tocuh "K" AOS vers.	559,00
0307	0C0041	0675838802		S					USER INTERFACE; LIV B	for Level B	332,90
0307	0C4891	0675854600			D	PDD2012-16			USER INTERFACE BOARD	for Level C	347,10
0307	0C6570			S					MOTHERBOARD; COP20-T	for Level TOUCH,K	426,30
0307	0C6571	0675837902	0C8805						USER INTERFACE BOARD; COPUI40-T	for Level TOUCH,K	
0307	0C7350			S					USER INTERFACE BOARD	For level c(start sn120...)	348,10
0308	0C0042	0675400200		S					POWER BOARD; COP20-A; LIV A/B/C LW	for Level B up to 4121...	588,00
0308	0C0042	0675400206		S					POWER BOARD; COP20-A; LIV A/B/C LW	for Level B from 4131...	588,00
0308	0C4890	0675854501	0C0042						POWER BOARD; COP20-C LIV.C AOSQ	for Level C	
0309	0C5833	0546824600							BUTTON EXTENSION; L=7,4MM		1,02
0311	005136	0652802200		S					FUSE; 5X20; 16A		1,47
0311	0C1480	0652803300		S					FUSE; 5*20 6,3A T; USA	For 208V-240V	1,25
0311	0C2301	0652803900		S					FUSE; OMEGA 800MA (COD. ST22180)		1,27
0312	0F0031	0652802100		S					FUSE CARRIER		16,08
0313	006314	0646810802		S					SAFETY THERMOSTAT; 338 C	For 208V	121,80
0313	007042	0646812200		S	C				SAFETY THERMOSTAT; 357°C		93,15
0314	002628	0508840801		S					FLANGE		4,01
0315	002627	0574804900		S		+			LAMP GLASS		10,24
0316	002626	0543817202		S		+			LAMP HOLDER GASKET		15,39

??????	267205											
??????	875400Y00		???????? 5				Electrical components					
.		Alias		S			.					(Euro)
0317	0C4396	0660808300	0C9877	S	C			HALOGEN LAMP; 12V-10W 300GR C.	Up to 4361...			
0317	0C9877	0660400100		S	C			HALOGEN LAMP; 12V 10W G4	From 4371...			7,46
0318	007105	0660806800		S				LAMP HOLDER				27,61
0319	0C1169	0538804000						THROTTLE				19,89
0320	0C5501	0680802300	0C0883					GEARMOTOR; 230V-50HZ				
0320	0C5502	0680802400	0C1479					GEARMOTOR; 24V-60HZ; USA	For 60Hz			
0321	0C2983	0646814900		S	C			OVERTEMPERATURE LIMITER; 140GR 3P				82,80
0322	0C1168	0543832200						GASKET				31,57
0323	0C1219	0831806402						PIPE				69,53
0324	0C4106	0624811000		S				FAN; 220/240V 50/60HZ				37,76
0325	049303	0694605400		S				RADIO INTERFERENCE FILTER; 250V 50/60HZ				23,55
0326	058707	0639805401		S				TERMINAL BOARD				47,60
0326	0C2243	0639810900						TERMINAL BOARD; 50 MM 150A USA	For 240V			145,10
0326	0C2673	0639811600						TERMINAL BOARD	For 208V			41,72
0326	0C9704	0639400900						TERMINAL BOARD; TXM 100 04 130A 600V	For Japan Version			133,00
0327	0C1186	0694800700		S				CONDENSER; 31.5 MF				19,18
0327	0C1187	0694802700		S				CAPACITOR; 15 MF				14,07
0328	0C0886	0624807901		S				TRANSFORMER;480VA 12/24/120/208/220/240	For 208V Version			212,10
0328	0C6400	0624400100		S		Kit		TRANSFORMER; KIT	Up to 329100..			76,73
0328	0C9557	0624400900	0C6400					TRANSFORMER; 100VA 230/10-24V 50-50VA	From to 330100..			
0328	0C9857	0624400B00	0C9865	S		+		TRANSFORMER;100/200/230V 10.5/24V 50/60H	For Japan Version			
0329	056466	0648802601		S				RELAY	For 208V-240V			26,29
0329	058857	0648803001		S				RELAY				25,12
0329	088267	0648722900		S				RELAY; COIL 200-240VAC	For 208V-240V			39,18
0330	007047	0624807002		S				POWER SUPPLY BOARD; LAMBDA PROBE				145,10
0331	006879	0648807400		S	C			CONTACTOR; 220-240V 50HZ/240-264V 60HZ	For 208V, Japan version			37,68
0331	007080	0648807700		S	C			CONTACTOR; 220-240V 50HZ/240-264 60HZ	For 208V, Japan version			79,89
0331	007104	0648807800		S	C			CONTACTOR; 220-240V 50HZ/240-264V 60HZ	For Lev A,B			115,60
0331	088477	0648807300		S	C			CONTACTOR; 220-240V 50HZ/240-264V 60HZ	For Lev A,B Japan version			28,84
0331	0C2244	0648808400		S	C			CONTACTOR; 220-240V 50HZ/240-264V 60HZ	For 208V, Japan version			159,80
0331	0L0355	0648613200		S	C	+		CONTACTOR; 220-240V 50HZ/240-264V 60HZ				68,73
0332	0C4459	0509803900		S				LAMP CAP				5,91
0333	000000											
0334	000000											
0335	0C6945	0624400000		S				TRANSFORMER; 450VA 12/24/120/208/220/240	For 208V,240V			218,20

??????	267205									
??????	875400Y00	???????? 5					Electrical components			
.		Alias		S			.			(Euro)
0336	0C1487	0652803400					FUSE CARRIER	For 208V,240V		117,70
0337	0C1488	0652803500		S			FUSE; 63A 22*58; USA	For 208V,240V		54,08
0338	0C6547	0546400200		S			BOWL; FOR USB	for TOUCH level		3,17
0339	0C6546	0541400A00		S			PLUG; PER USB	for TOUCH level		5,29
0340	0C5451	0543843500		S			LAMP HOLDER GASKET			4,54
0341	0C8033	0675858601		S			BUTTON; 0/I; TOUCH	For TOUCH level		52,27
0342	088267	0648722900		S			RELAY; COIL 200-240VAC			39,18
0343	0C6566	0638400Y00		S			USB EXTENSION; L=340MM	For Touch level		12,46
0344	0C4937	0831851301		S	C		AIR FILTER; 202 'ONE'			68,00
0345	0C9992	0549400K00					CONTROL PANEL FILTER; L=417MM			7,89



PLATON SERVICE
 8 (800) 500-34-41
 www.platonservice.com

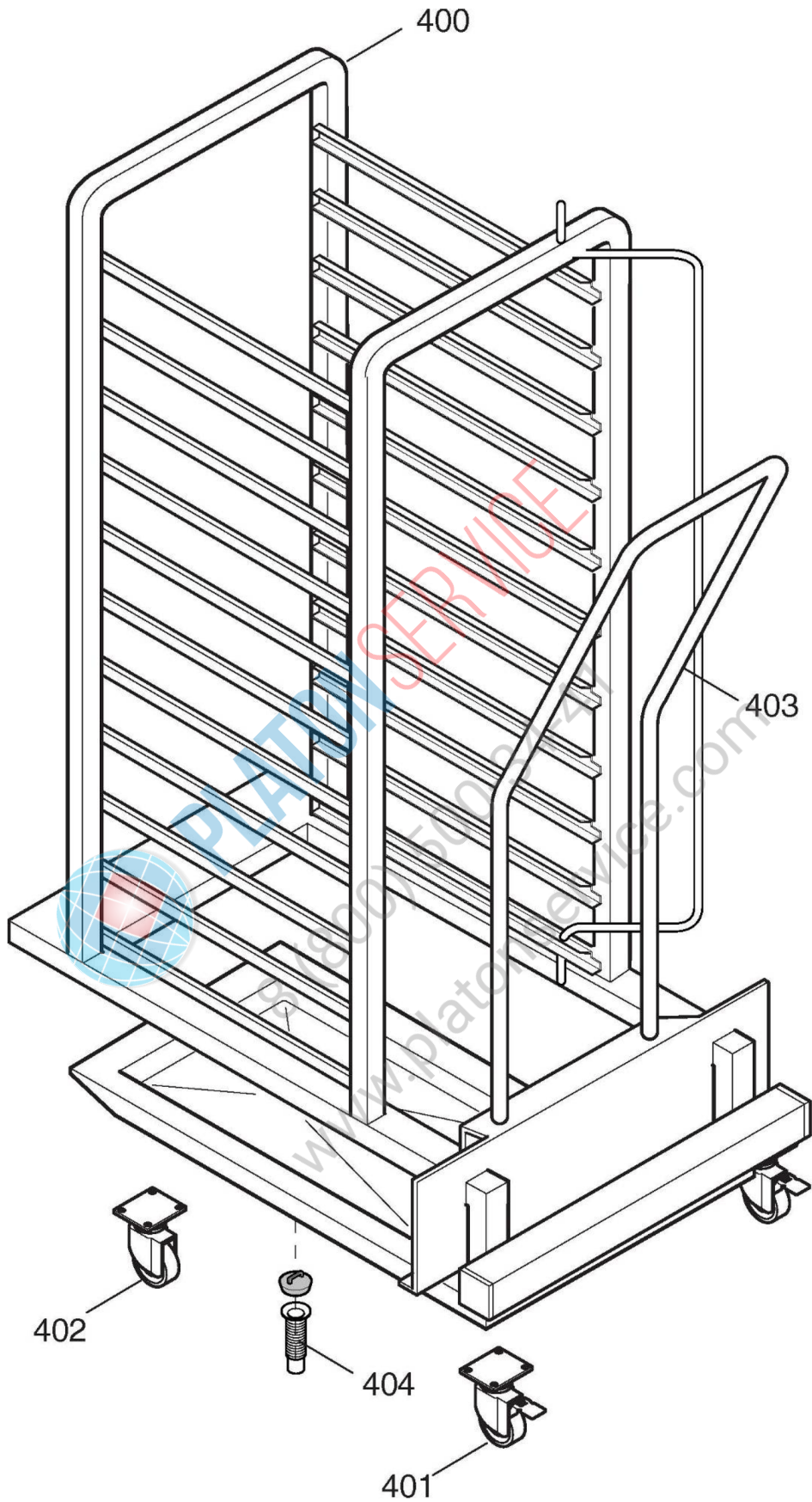

From sr. Nr/ Da Ser. Nr.: ***
From status level / Da scatto: 07

Page: 6

Ed. 2014 10

Doc. Nr.: **875400Y00**

??????	267205								
??????	875400Y00	???????? 6	Accessories						
.		Alias		S			.		(Euro)
0400	0C1197	0853861303						TROLLEY	2 263,00
0401	0C1631	0835865000		S				CASTOR WITH BRAKE; DIA 100MM	37,56
0402	0C2216	0835865800		S				CASTOR; D125 W/PLATE F140 D4 125E	29,44
0403	0C4682	0517878001			D			HANDLE	140,10
0404	006309	0H21503300		S				TUB DRAIN	34,10
0404	0C0325	0830899001		S				TEMP.PROBE; THERMOCOUPLE; L=85CM; BOILER	for Level TOUCH e B 39,89
0404	0C6539	0830899101		S				THERMOCOUPLE PROBE; L=1100MM; STRAIGHT	for Level TOUCH e B 40,19
0404	0C7028	0830400N00		S				SENSOR	42,12



PLATON SERVICE

8 (800) 500-34-47

www.platonservice.com